

1250 | 1251 | 1252 FACET

1250 SMALL FACET: 42 lbs. Aluminum CAPACITY: 10.4 cu ft DIMENSION: DIA 36" H 17.625"
1251 MEDIUM FACET: 61 lbs. Aluminum CAPACITY: 17.5 cu ft DIMENSION: DIA 36" H 29.625"
1252 LARGE FACET: 134 lbs. Aluminum CAPACITY: 29.5 cu ft DIMENSION: DIA 36" H 50"

Formed of either steel or aluminum, our containers are shaped, welded, powder coated (as desired), and packaged exclusively at Ore's independent manufacturing facility in Woods Cross, UT. For more information, please contact your Sales Representative.

OPTIONS:      

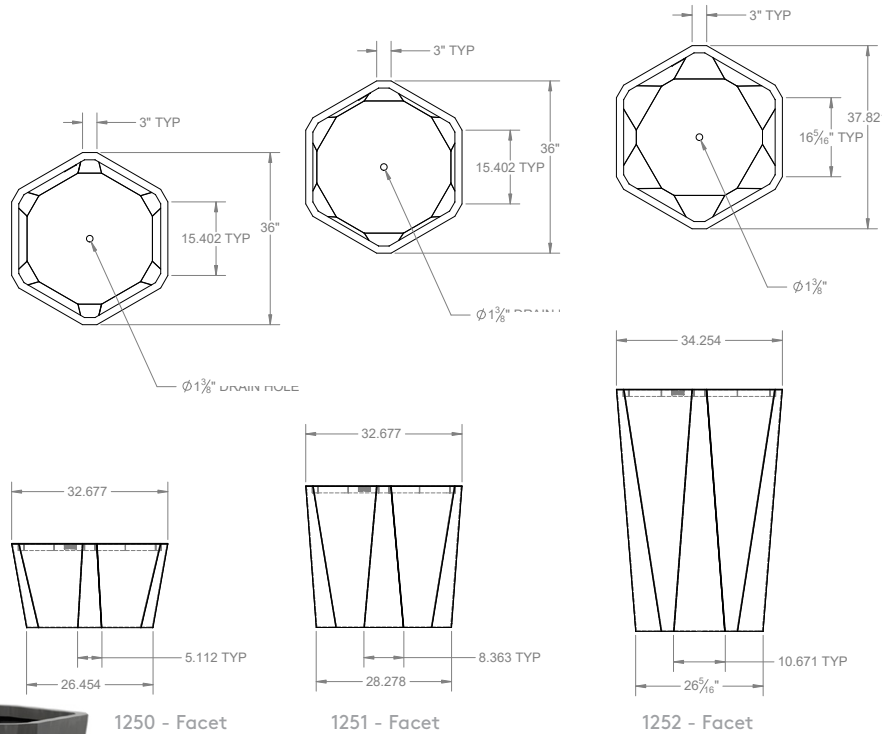

1250-1252 | Facet in Satin White

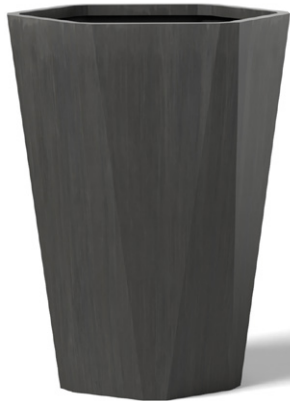

1250 - Facet

1251 - Facet

1252 - Facet

LEED® POINTS:

- 1) Material Content
- 2) Indoor Environmental Quality - Manufacturing
- 3) Indoor Environmental Quality - Low VOCs
- 4) Material Reuse
- 5) Proximity

Final points achieved will vary according to materials and destination.

LEGAL INFORMATION:

ALL RIGHTS RESERVED. INFORMATION IN THIS DOCUMENT IS CONFIDENTIAL AND IS EXCLUSIVE PROPERTY OF ORE INCORPORATED. DELIVERY OF THIS DOCUMENT OR ANY COPY THEREOF OR DISCLOSURE OF SUCH INFORMATION TO UNAUTHORIZED PERSONS IS FORBIDDEN WITHOUT EXPRESSED WRITTEN PERMISSION OF ORE INC.

TO SPECIFY THIS PRODUCT:

- 1) Indicate product name, product number, description, and size.
- 2) Select material: recycled steel, COR-TEN, or recycled aluminum. If recycled steel or aluminum is specified, select powder-coat color or natural patina finish.
- 3) Select product-specific options. Standard options may be viewed at ore.design.