

1114 | 1115 SLAB

PRODUCT DESCRIPTION: The SLAB planter group provides deep forms and horizontal lines. Available in a variety of colors, SLAB planters work equally well for indoor or outdoor applications.

1114 SMALL SLAB: WEIGHT: 54 lbs. Steel, 25 lbs. Aluminum CAPACITY: 1.75 cu ft DIMENSION: 30"L x 10"W x 24"H

1115 LARGE SLAB: WEIGHT: 81 lbs. Steel, 32 lbs. Aluminum CAPACITY: 2 cu ft DIMENSION: 36"L x 10"W x 30"H

Formed of either steel or aluminum, our SLAB containers are shaped, welded, powder coated (as desired), and packaged exclusively at Ore's independent manufacturing facility in Salt Lake City, Utah.

For more information, please contact your Ore Project Manager.

OPTIONS:      

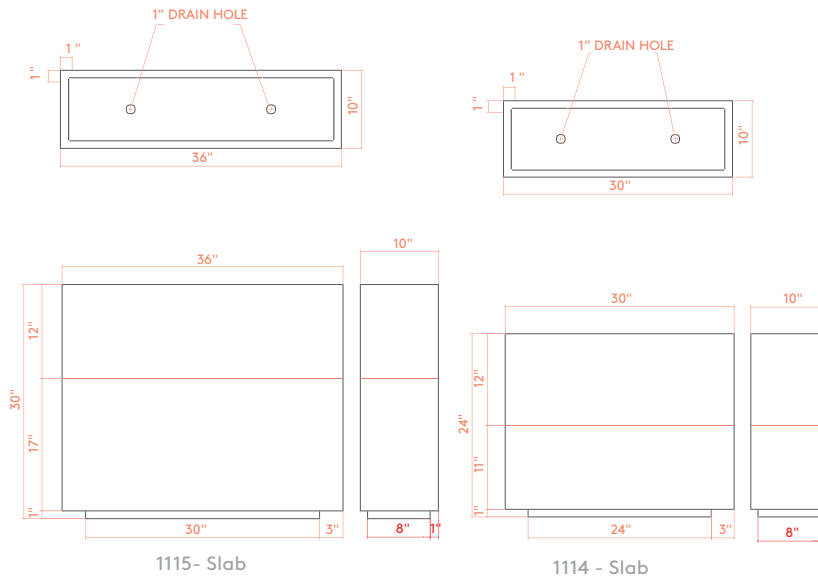

1115 | Large Slab in Standard Powder Coat Metallic Silver

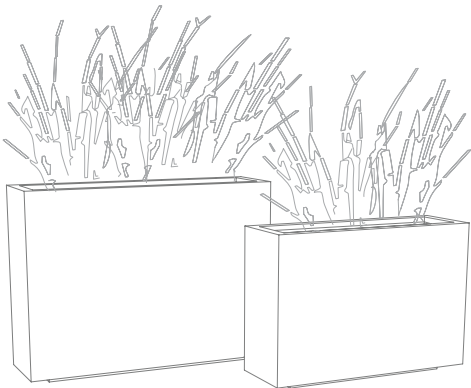

LEED® POINTS:

- 1) Material Content
- 2) Indoor Environmental Quality - Manufacturing
- 3) Indoor Environmental Quality - Low VOCs
- 4) Material Reuse
- 5) Proximity

Final points achieved will vary according to materials and destination.

LEGAL INFORMATION:

ALL RIGHTS RESERVED. INFORMATION IN THIS DOCUMENT IS CONFIDENTIAL AND IS EXCLUSIVE PROPERTY OF ORE INCORPORATED. DELIVERY OF THIS DOCUMENT OR ANY COPY THEREOF OR DISCLOSURE OF SUCH INFORMATION TO UNAUTHORIZED PERSONS IS FORBIDDEN WITHOUT EXPRESSED WRITTEN PERMISSION OF ORE INC.

TO SPECIFY THIS PRODUCT:

- 1) Indicate product name, product number, description, and size.
- 2) Select material: recycled steel, COR-TEN, or recycled aluminum. If recycled steel or aluminum is specified, select powder-coat color or natural patina finish.
- 3) Select product-specific options. Standard options may be viewed at ore.design.