

4020 LINEAR FIRE PIT

PRODUCT DESCRIPTION: The LINEAR FIRE PIT offers a low profile and sleek, horizontal lines. This product may be fitted with a CSA certified match-lit natural gas/LP linear burner or electronic pilotless ignition system.

CAUTION: Please follow operating instructions carefully. Firepits are for outdoor/interior use only.

4020 Linear Fire Pit: WEIGHT: 220 lbs. Steel | 95 lbs. Aluminum CAPACITY: 0.25 cu ft DIMENSION: 59"L x 22"W x 17"H (+ .5" H w/ floating aluminum top)
 *Standard Glass Rock: 0.5" - 1" glass rock, 3" deep. Available colors include: brown, black, blue, green, pearl, pink, purple, teal, turquoise & white
 *Premium Glass Rock: 0.5" - 1" glass rock, 3" deep. Available colors include: red, yellow and orange. *Lava Rock: 1"-2", natural buff
 *Granite Top adds approximately 70 lbs to the final weight.

Formed of either steel or aluminum, our containers and outdoor products are shaped, welded, powder coated (as desired), and packaged exclusively at Ore's independent manufacturing facility in Salt Lake City, Utah.
 For more information, please contact your Ore Project Manager.

OPTIONS:      

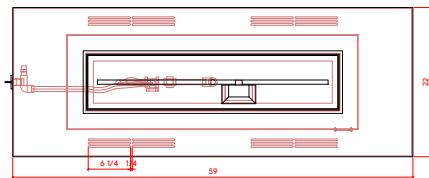

PLAN

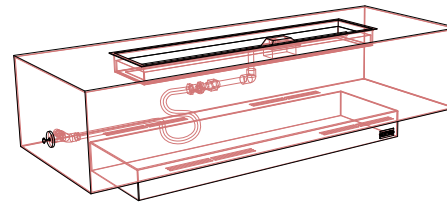

PERSPECTIVE

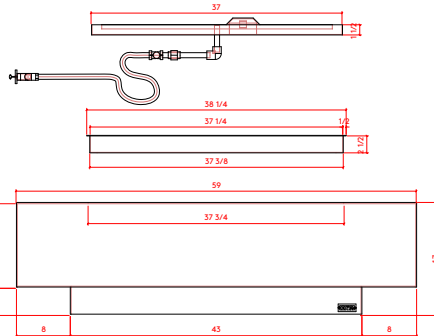

FRONT ELEVATION

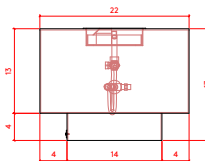

RIGHT ELEVATION



4020 | Linear Fire Pit with
Raised Aluminum Top (Option) in
Standard Powder Coat White

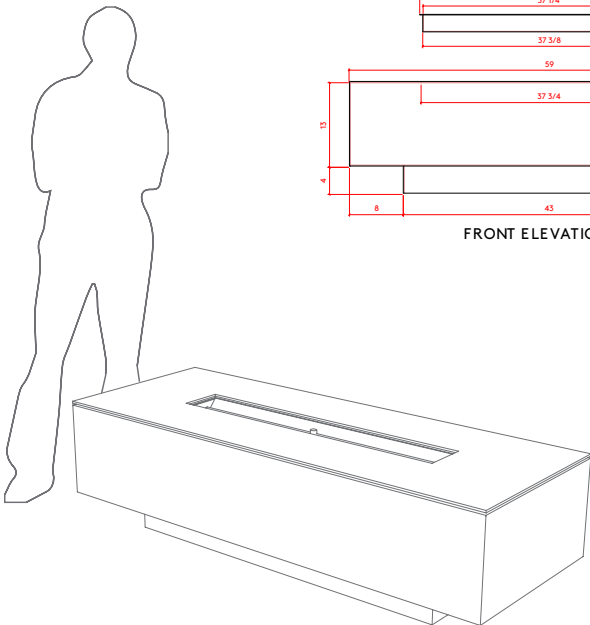

LEED® POINTS:

- 1) Material Content
- 2) Indoor Environmental Quality - Manufacturing
- 3) Indoor Environmental Quality - Low VOCs
- 4) Material Reuse
- 5) Proximity

Final points achieved will vary according to materials and destination.

LEGAL INFORMATION:

ALL RIGHTS RESERVED. INFORMATION IN THIS DOCUMENT IS CONFIDENTIAL AND IS EXCLUSIVE PROPERTY OF ORE INCORPORATED. DELIVERY OF THIS DOCUMENT OR ANY COPY THEREOF OR DISCLOSURE OF SUCH INFORMATION TO UNAUTHORIZED PERSONS IS FORBIDDEN WITHOUT EXPRESSED WRITTEN PERMISSION OF ORE INC.

TO SPECIFY THIS PRODUCT:

- 1) Indicate product name, product number, description, and size.
- 2) Select material: recycled steel, COR-TEN, or recycled aluminum. If recycled steel or aluminum is specified, select powder-coat color or natural patina finish.
- 3) Select product-specific options. Standard options may be viewed at ore.design.

4020 LINEAR FIRE PIT

Standard Options: The LINEAR FIRE PIT base model is provided with a CSA certified, 65 k B.T.U. match-lit burner (see first page for dimensions). A removable cover is required with an electronic ignition burner. While firepit dimensions do not change with each option, there may be variations on the top face when selecting your burner. Our Project Managers are on hand to discuss additional options to complement your burner selection.

Please note that firepits are for outside use only, regardless of burner selection.

CSA CERTIFIED MATCH LIT LINEAR BURNER

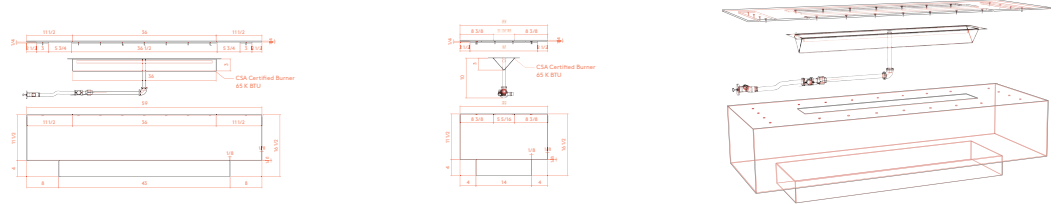

PILOTLESS REMOTE ELECTRONIC IGNITION

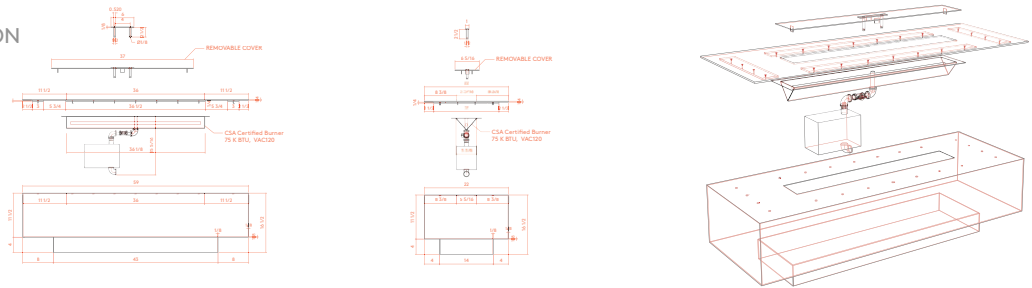

GLASS SURROUND

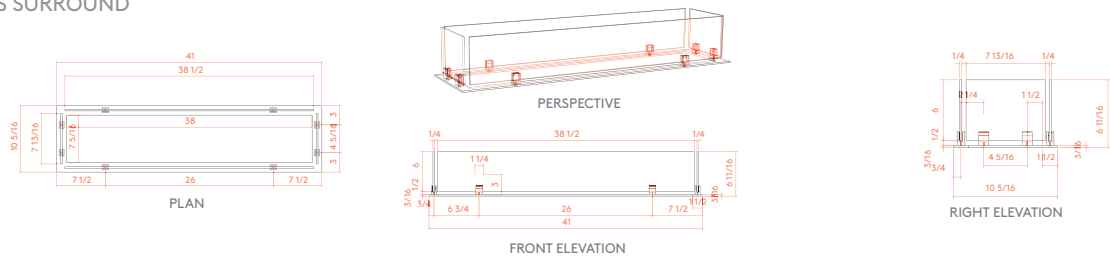

4020 | Linear Fire Pit with
Raised Aluminum Top (Option) in
Standard Powder Coat White

LEGAL INFORMATION:

ALL RIGHTS RESERVED. INFORMATION IN THIS DOCUMENT IS CONFIDENTIAL AND IS EXCLUSIVE PROPERTY OF ORE INCORPORATED. DELIVERY OF THIS DOCUMENT OR ANY COPY THEREOF OR DISCLOSURE OF SUCH INFORMATION TO UNAUTHORIZED PERSONS IS FORBIDDEN WITHOUT EXPRESSED WRITTEN PERMISSION OF ORE INC.