

## 4016 RECTANGLE FIRE PIT

**PRODUCT DESCRIPTION:** The RECTANGLE FIRE PIT highlights sleek lines with raised, glass panels that add an elegant visual element. This firepit may be fitted for natural gas or EcoSmart bioethanol.

**CAUTION:** Please follow operating instructions carefully. Firepits are for outdoor/interior use only.

**4016 RECTANGLE FIRE PIT:** WEIGHT: 115 lbs. Steel | 58 lbs. Aluminum CAPACITY: 0.25 cu ft DIMENSION: 43”L x 28”W x 18”H  
 \*Standard Glass Rock: 0.5” - 1” glass rock, 3” deep. Available colors include: brown, black, blue, green, pearl, pink, purple, teal, turquoise & white  
 \*Premium Glass Rock: 0.5” - 1” glass rock, 3” deep. Available colors include: red, yellow and orange \*Lava Rock: 1”-2”, natural buff \*Granite Top adds approximately 70 lbs to the final weight.

Formed of either steel or aluminum, our containers and outdoor products are shaped, welded, powder coated (as desired), and packaged exclusively at Ore’s independent manufacturing facility in Salt Lake City, Utah.  
 For more information, please contact your Ore Project Manager.

OPTIONS:         

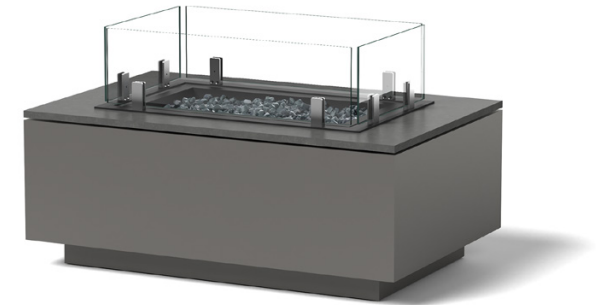
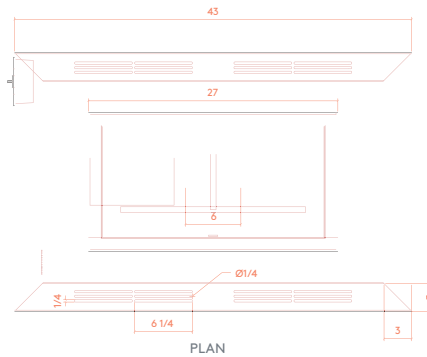
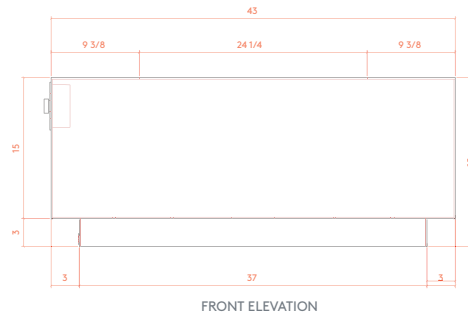
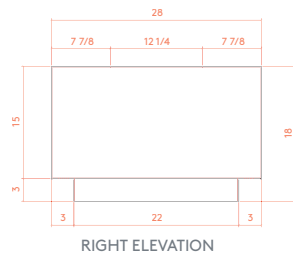

4016 | Rectangle Fire Pit in Standard Powder Coat Charcoal Gray

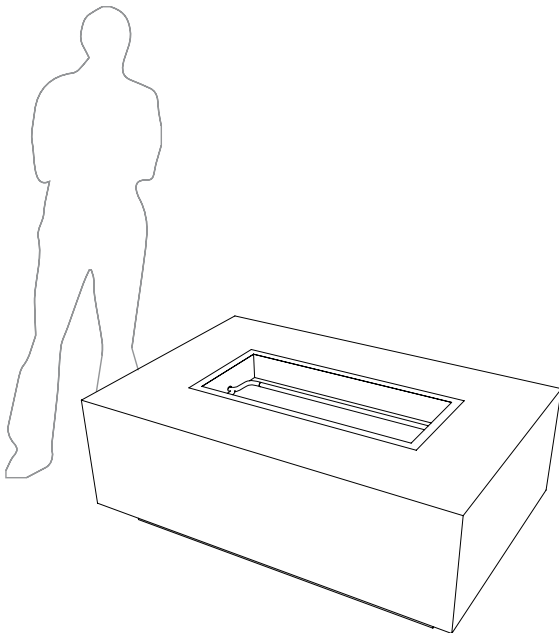

**LEED® POINTS:**

- 1) Material Content
- 2) Indoor Environmental Quality - Manufacturing
- 3) Indoor Environmental Quality - Low VOCs
- 4) Material Reuse
- 5) Proximity

Final points achieved will vary according to materials and destination.

**LEGAL INFORMATION:**

ALL RIGHTS RESERVED. INFORMATION IN THIS DOCUMENT IS CONFIDENTIAL AND IS EXCLUSIVE PROPERTY OF ORE INCORPORATED. DELIVERY OF THIS DOCUMENT OR ANY COPY THEREOF OR DISCLOSURE OF SUCH INFORMATION TO UNAUTHORIZED PERSONS IS FORBIDDEN WITHOUT EXPRESSED WRITTEN PERMISSION OF ORE INC.

**TO SPECIFY THIS PRODUCT:**

- 1) Indicate product name, product number, description, and size.
- 2) Select material: recycled steel, COR-TEN, or recycled aluminum. If recycled steel or aluminum is specified, select powder-coat color or natural patina finish.
- 3) Select product-specific options. Standard options may be viewed at [ore.design](http://ore.design).

## 4016 RECTANGLE FIRE PIT

**Standard Options:** The RECTANGLE FIRE PIT may be fitted with the options below. While firepit dimensions do not change with each option, there may be variations on the top face when selecting your burner. Our Project Managers are on hand to discuss additional options to complement your burner selection.

Please note that firepits are for outside use only, regardless of burner selection.

### CSA CERTIFIED MATCH LIT BURNER

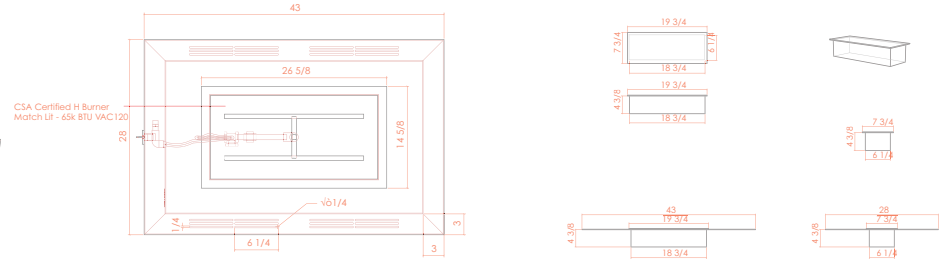
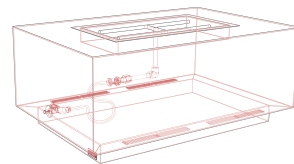
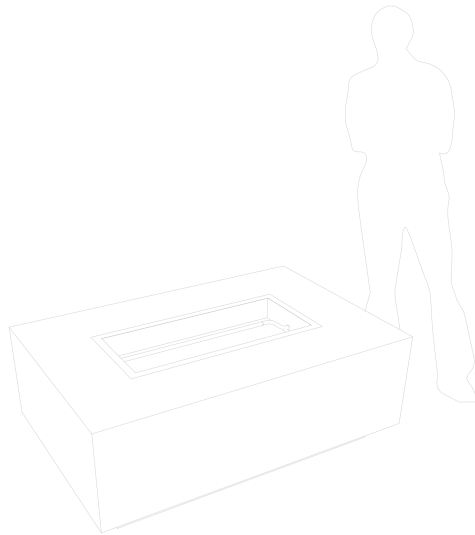

### PILOTLESS REMOTE ELECTRONIC IGNITION

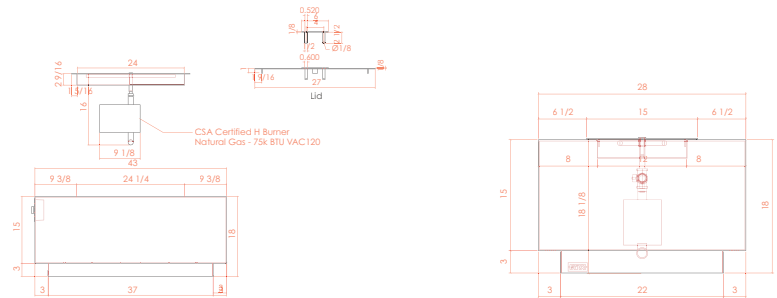
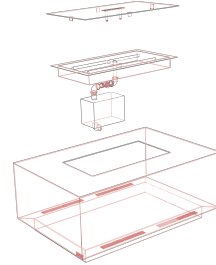

### GLASS SURROUND

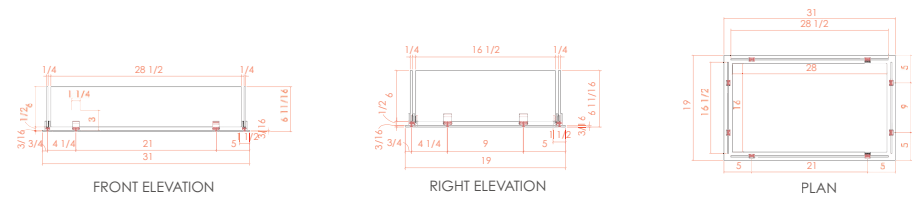
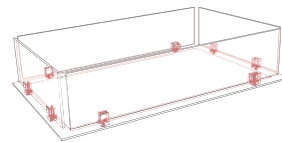
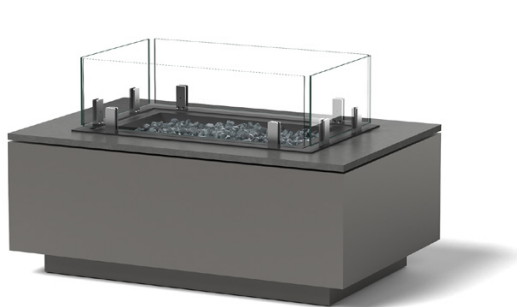

4016 | Rectangle Fire Pit in Standard Powder Coat Charcoal Gray

**LEGAL INFORMATION:**  
ALL RIGHTS RESERVED. INFORMATION IN THIS DOCUMENT IS CONFIDENTIAL AND IS EXCLUSIVE PROPERTY OF ORE INCORPORATED. DELIVERY OF THIS DOCUMENT OR ANY COPY THEREOF OR DISCLOSURE OF SUCH INFORMATION TO UNAUTHORIZED PERSONS IS FORBIDDEN WITHOUT EXPRESSED WRITTEN PERMISSION OF ORE INC.