

4015 BLOCK FIRE PIT

PRODUCT DESCRIPTION: The BLOCK FIRE PIT is a versatile outdoor element, featuring a low profile, square form, and many color options. This firepit may be fitted for natural gas, propane (LP), or EcoSmart bioethanol .

CAUTION: Please follow operating instructions carefully. Firepits are for outdoor/exterior use only.

4015 BLOCK FIRE PIT: WEIGHT: 125 lbs. Steel | 60 lbs. Aluminum CAPACITY: 0.25 cu ft DIMENSION: 36”L x 36”W x 18”H

*Standard Glass Rock: 0.5” - 1” glass rock, 3” deep. Available colors include: brown, black, blue, green, pearl, pink, purple, teal, turquoise & white

*Premium Glass Rock: 0.5” - 1” glass rock, 3” deep. Available colors include: red, yellow and orange *Granite Top adds approximately 85 lbs to the final weight.

Formed of either steel or aluminum, our containers and outdoor products are shaped, welded, powder coated (as desired), and packaged exclusively at Ore’s independent manufacturing facility in Salt Lake City, Utah.

For more information, please contact your Ore Project Manager.

OPTIONS:        

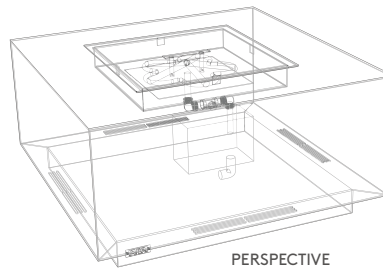
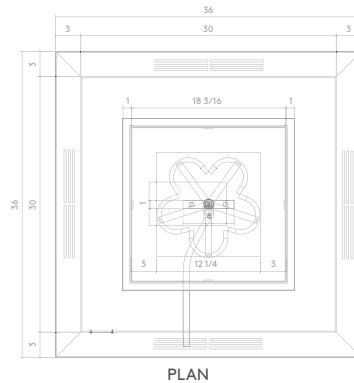

4015 | Block Fire Pit in Oxidized Zinc Patina

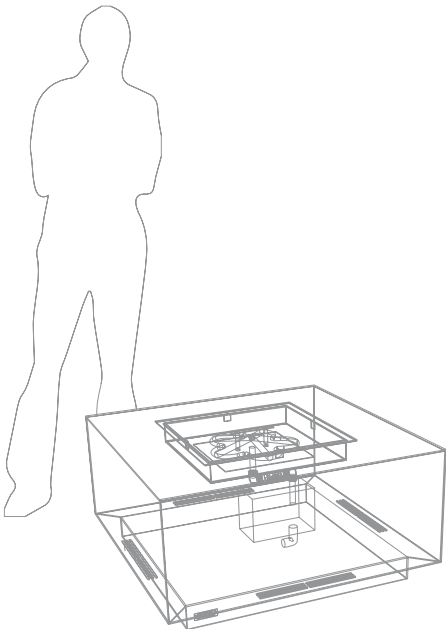

LEED® POINTS:

- 1) Material Content
- 2) Indoor Environmental Quality - Manufacturing
- 3) Indoor Environmental Quality - Low VOCs
- 4) Material Reuse
- 5) Proximity

Final points achieved will vary according to materials and destination.

LEGAL INFORMATION:

ALL RIGHTS RESERVED. INFORMATION IN THIS DOCUMENT IS CONFIDENTIAL AND IS EXCLUSIVE PROPERTY OF ORE INCORPORATED. DELIVERY OF THIS DOCUMENT OR ANY COPY THEREOF OR DISCLOSURE OF SUCH INFORMATION TO UNAUTHORIZED PERSONS IS FORBIDDEN WITHOUT EXPRESSED WRITTEN PERMISSION OF ORE INC.

TO SPECIFY THIS PRODUCT:

- 1) Indicate product name, product number, description, and size.
- 2) Select material: recycled steel, COR-TEN, or recycled aluminum. If recycled steel or aluminum is specified, select powder-coat color or natural patina finish.
- 3) Select product-specific options. Standard options may be viewed at ore.design.

4015 BLOCK FIRE PIT

Standard Options: The BLOCK FIRE PIT base model may be fitted with the options below. While firepit dimensions do not change with each option, there may be variations on the top face when selecting your burner. Our Project Managers are on hand to discuss additional options to complement your burner selection.

Please note that firepits are for outside use only, regardless of burner selection.

CSA CERTIFIED MATCH LIT BURNER

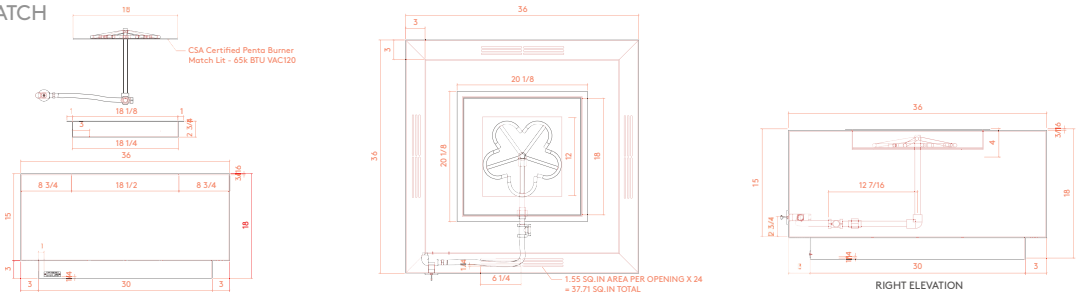

CSA CERTIFIED PILOTLESS REMOTE ELECTRONIC IGNITION

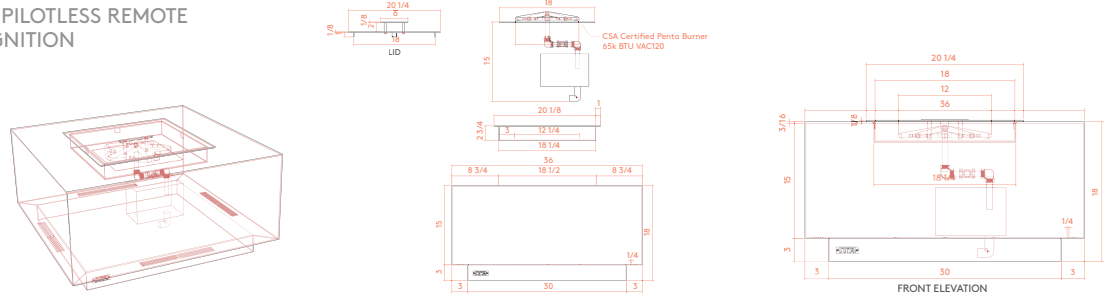

GLASS SURROUND

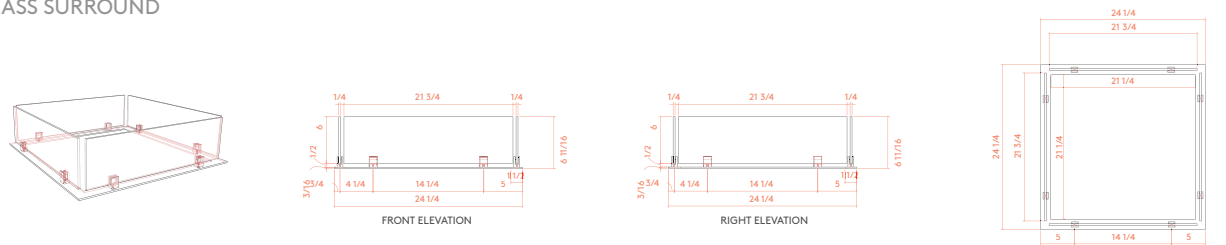

4015 | Block Fire Pit in Oxidized Zinc Patina

LEGAL INFORMATION:

ALL RIGHTS RESERVED. INFORMATION IN THIS DOCUMENT IS CONFIDENTIAL AND IS EXCLUSIVE PROPERTY OF ORE INCORPORATED. DELIVERY OF THIS DOCUMENT OR ANY COPY THEREOF OR DISCLOSURE OF SUCH INFORMATION TO UNAUTHORIZED PERSONS IS FORBIDDEN WITHOUT EXPRESSED WRITTEN PERMISSION OF ORE INC.

4025 BLOCK FIRE PIT

PRODUCT DESCRIPTION: The larger version of our BLOCK FIRE PIT is a versatile outdoor element, featuring prominent, square form, and many color options. This firepit may be fitted for natural gas, propane (LP), or EcoSmart bioethanol.

CAUTION: Please follow operating instructions carefully. Firepits are for outdoor/exterior use only.

4025 Block Fire Pit: 295 lbs. Steel | 165 lbs. Aluminum CAPACITY: 0.25 cu ft DIMENSION: 48"L x 48"W x 18"H

*Standard Glass Rock: 0.5" - 1" glass rock, 3" deep. Available colors include: brown, black, blue, green, pearl, pink, purple, teal, turquoise & white

*Premium Glass Rock: 0.5" - 1" glass rock, 3" deep. Available colors include: red, yellow and orange

*Granite Top adds approximately 85 lbs to the final weight.

Formed of either steel or aluminum, our containers and outdoor products are shaped, welded, powder coated (as desired), and packaged exclusively at Ore's independent manufacturing facility in Salt Lake City, Utah.

OPTIONS:      

For more information, please contact your Ore Project Manager.

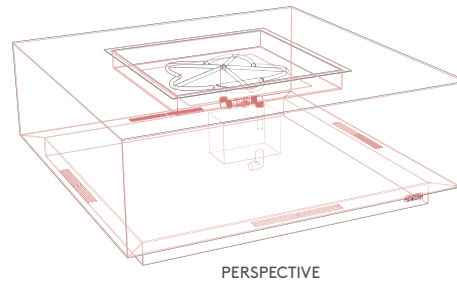
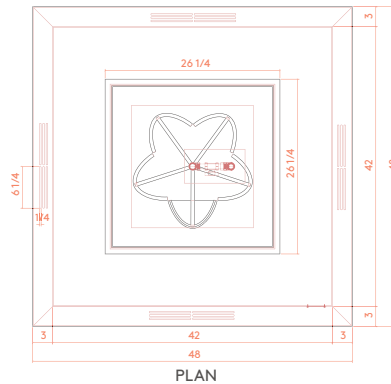

4025 | Block Fire Pit in Oxidized Zinc Patina

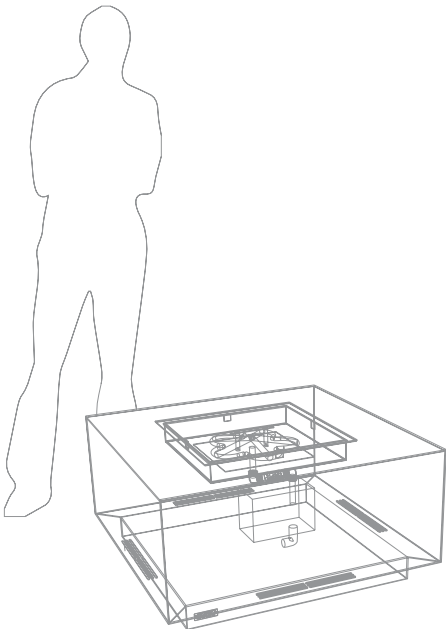

LEED® POINTS:

- 1) Material Content
- 2) Indoor Environmental Quality - Manufacturing
- 3) Indoor Environmental Quality - Low VOCs
- 4) Material Reuse
- 5) Proximity

Final points achieved will vary according to materials and destination.

LEGAL INFORMATION:

ALL RIGHTS RESERVED. INFORMATION IN THIS DOCUMENT IS CONFIDENTIAL AND IS EXCLUSIVE PROPERTY OF ORE INCORPORATED. DELIVERY OF THIS DOCUMENT OR ANY COPY THEREOF OR DISCLOSURE OF SUCH INFORMATION TO UNAUTHORIZED PERSONS IS FORBIDDEN WITHOUT EXPRESSED WRITTEN PERMISSION OF ORE INC.

TO SPECIFY THIS PRODUCT:

- 1) Indicate product name, product number, description, and size.
- 2) Select material: recycled steel, COR-TEN, or recycled aluminum. If recycled steel or aluminum is specified, select powder-coat color or natural patina finish.
- 3) Select product-specific options. Standard options may be viewed at ore.design.

4025 BLOCK FIRE PIT

CAUTION: Firepits are for outside use only, regardless of burner selection.

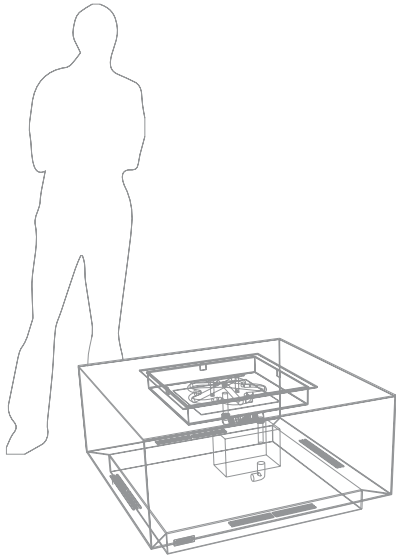

CSA CERTIFIED MATCH LIT BURNER

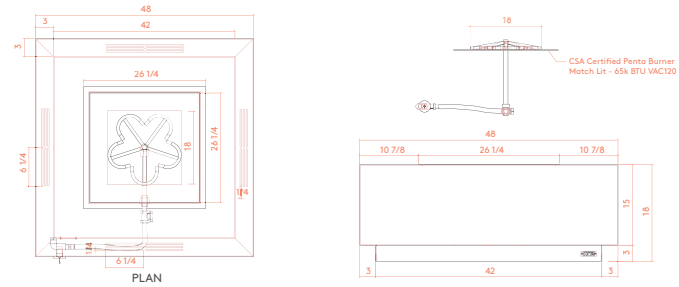

CSA CERTIFIED PILOTLESS REMOTE ELECTRONIC IGNITION

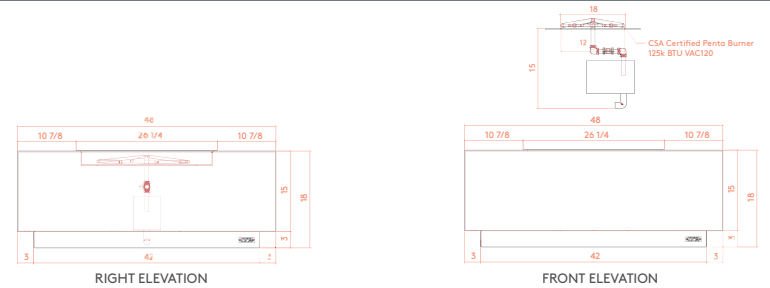
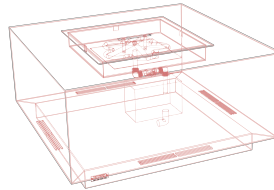

GLASS SURROUND

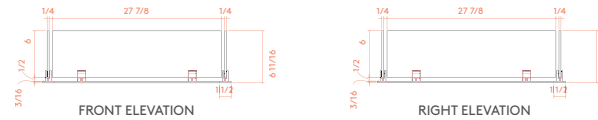
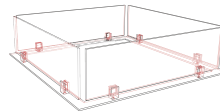

4025 | Block Fire Pit in Oxidized Zinc Patina

LEGAL INFORMATION:

ALL RIGHTS RESERVED. INFORMATION IN THIS DOCUMENT IS CONFIDENTIAL AND IS EXCLUSIVE PROPERTY OF ORE INCORPORATED. DELIVERY OF THIS DOCUMENT OR ANY COPY THEREOF OR DISCLOSURE OF SUCH INFORMATION TO UNAUTHORIZED PERSONS IS FORBIDDEN WITHOUT EXPRESSED WRITTEN PERMISSION OF ORE INC.