

## 1024 DOUBLE GROOVE

**PRODUCT DESCRIPTION:** The DOUBLE GROOVE container features a low, deep form and the signature design feature of pronounced channels cut in bands near the top and bottom of the container. The DOUBLE GROOVE is available in a variety of colors.

**1024 DOUBLE GROOVE:** WEIGHT: 95 lbs. Steel | 40 lbs. Aluminum CAPACITY: 10 cu ft DIMENSION: 27"L x 27"W x 28"H

Formed of either steel or aluminum, our DOUBLE GROOVE containers are shaped, welded, powder coated (as desired), and packaged exclusively at Ore's independent manufacturing facility in Salt Lake City, Utah. For more information, please contact your Ore Project Manager.

**OPTIONS:** 🔊 💡 📱 🔌 🔥 📄 📺 🔒

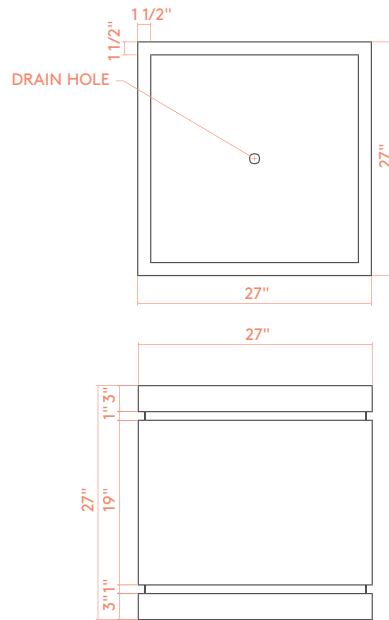

1024 - Double Band



1024 | Double Groove in Standard Hammered Bronze Powder Coat

**LEED® POINTS:**

- 1) Material Content
- 2) Indoor Environmental Quality - Manufacturing
- 3) Indoor Environmental Quality - Low VOCs
- 4) Material Reuse
- 5) Proximity

Final points achieved will vary according to materials and destination.

**LEGAL INFORMATION:**

ALL RIGHTS RESERVED. INFORMATION IN THIS DOCUMENT IS CONFIDENTIAL AND IS EXCLUSIVE PROPERTY OF ORE INCORPORATED. DELIVERY OF THIS DOCUMENT OR ANY COPY THEREOF OR DISCLOSURE OF SUCH INFORMATION TO UNAUTHORIZED PERSONS IS FORBIDDEN WITHOUT EXPRESSED WRITTEN PERMISSION OF ORE INC.

**TO SPECIFY THIS PRODUCT:**

- 1) Indicate product name, product number, description, and size.
- 2) Select material: recycled steel, COR-TEN, or recycled aluminum. If recycled steel or aluminum is specified, select powder-coat color or natural patina finish.
- 3) Select product-specific options. Standard options may be viewed at [ore.design](http://ore.design).